

2016

Mechanisms of Vortex Oscillation in a Fluidic Flow Meter

Mohammed Al-Muqbel
University of Central Florida

Peshala Gamage
University of Central Florida

Find similar works at: <https://stars.library.ucf.edu/urj>
University of Central Florida Libraries <http://library.ucf.edu>

This Article is brought to you for free and open access by the Office of Undergraduate Research at STARS. It has been accepted for inclusion in The Pegasus Review: UCF Undergraduate Research Journal (URJ) by an authorized editor of STARS. For more information, please contact STARS@ucf.edu.

Recommended Citation

Al-Muqbel, Mohammed and Gamage, Peshala (2016) "Mechanisms of Vortex Oscillation in a Fluidic Flow Meter," *The Pegasus Review: UCF Undergraduate Research Journal (URJ)*: Vol. 9 : Iss. 2 , Article 1.
Available at: <https://stars.library.ucf.edu/urj/vol9/iss2/1>

Mechanisms of Vortex Oscillation in a Fluidic Flow Meter

By: Mohammed Al-Muqbel and Peshala Gamage

Faculty Mentor: Dr. Hansen Mansy

UCF Department of Mechanical and Aerospace Engineering

.....

ABSTRACT: Flow meters are devices capable of measuring the amount of fluid transported through piping networks. Example applications include accurate measurements of flow in chemical processing plants and fluid consumption by end-users (e.g. water, fuel, natural gas, etc.) by customers, which is a core issue in fluid-handling engineering. Some flow meters contain no moving parts (Royle and Boucher 1972), which is desirable since moving parts wear over time, leading to compromised meter accuracy. The meter investigated in this study contains no moving parts, and its operation relies on oscillations induced by the fluid flow through the meter. In this project, the mechanism of the underlying flow-induced oscillations was investigated both experimentally and using computer simulations. Measurements showed that the oscillating frequency was a linear function of the flow rate, which implies that the oscillating cycle corresponds to a fixed amount of fluid irrespective of the flow rate (Mansy and Williams 1989). This mechanism makes the device a good fit as a totalizing meter since by counting the number of cycles, the total amount of fluid consumed can be determined. The computer model was validated using experimental measurements. The model results showed that fluid oscillations tended to be weaker at low Reynolds numbers, which will help determine the useful working range of the device.

KEYWORDS: flow meter, fluids, engineering, oscillation, frequency, simulation, experiment, cycles, device

..... *Republication not permitted without written consent of the author.*

INTRODUCTION

A flow meter is an instrument used to measure the flow rate of a fluid. Diverse applications often require new methods of measuring flow rates, which have led to the development and emergence of different types of flow meters. Flow meters are also commercially important. They allow for monitoring the consumption of gas, water, and fuel. In addition, flow meters can be implemented to safely control the amount of flow in a piping system in factories and plants. They are also used in health-care applications, such as measuring breathing flows to identify health issues in respiratory system.

There are two ways of measuring flow. One way is to directly measure the flow using a container with a known volume and a stopwatch. However, this traditional way may lack accuracy as it involves several errors that arise from human reaction time and concurrency in measuring time and volume. Also this approach can only provide an average rather than a time-dependent flow rate value. Alternatively, flow rates can be measured indirectly using working flow principles, such as relations between flow rate and pressure differentials. The latter technique can provide dynamic flow rate values and reduce human errors (Cengel and Cimbala 2006).

Flow meters can be classified per their construction and if they contain moving parts. Examples of moving-parts flow meters include turbine, positive displacement, and some electromagnetic flow meters. Non-moving parts flow meters include flow nozzles, venturi meters, orifice meters, and the one investigated in this paper (Pritchard 2011). Both types of flow meters have advantages and disadvantages. Thus, to determine the optimal type of flow meter most suitable for an application, a thorough analysis and evaluation of the meter should be carried out. In this study, we explore a non-moving-part flow meter that mainly relies on the frequency of the flow oscillation that is induced by the fluid as it flows through the device.

FLOW METER GEOMETRY

Figures 1 and 2 both show a 3D-printed model of the flow meter. This flow meter was designed specially to fit an application with a certain pipe size. The inlet and outlet were modelled to allow a 1-inch diameter tube to be attached to them. To facilitate flow visualization, we made a recess with a height of about 2mm on the top of the side walls of the device to allow for a laser-cut

sheet to securely cover the top of the meter. The device body was made of ABS plastic, while the cover was made of acrylic glass that was tightly sealed with clear silicon paste. The main dimensions of the meter are listed in Table 1.

METHODS

Experimental Setup

Figure 3 shows the experimental setup. More specifically, the experiment was done in an open-loop configuration without need for a pump. Here, a 1-inch diameter tube connected the flow meter to a faucet. To facilitate flow visualization, a syringe was inserted in the tube (as seen in Fig. 3) to carefully inject ink in the flow direction. Also, a beaker and stop-watch were used to collect the outflow water from the flow meter and measure the time, respectively.

In addition, we used a 240 frame/s camera to record the oscillation of the water jet inside the flow meter. In all, we tested a total of 6 different flow rates. The flow rate was then plotted against the frequency of oscillation of the jet. These results will be compared with the numerical solution.

CFD Analysis

Transient, laminar, and incompressible flow is assumed¹. The governing equations for mass continuity (eqn.1) and momentum conservation (eqn.2) are solved using commercial package Fluent(ANSYS).

$$\frac{\partial u_i}{\partial x_i} = 0 \quad (1)$$

$$\rho \frac{\partial u_i}{\partial t} + \rho u_j \frac{\partial u_i}{\partial x_j} = -\frac{\partial P}{\partial x_i} + \mu \frac{\partial^2 u_i}{\partial x_j \partial x_j} \quad (2)$$

u and P are the three-dimensional velocity vector and the static pressure, respectively. For this simulation, the density, ρ , was chosen to be 998.2 kgm^{-3} and the dynamic viscosity, μ , was selected as $1.003\text{e-}03 \text{ kg/(ms)}$.

¹ We made these simplifying assumptions for the following reasons:
Transient: The experiment is being done over a fixed period so it is important to capture the flow variations over time.
Laminar: This assumption was made to reduce computing power and simplify the solution as the expected results may not be dramatically different than turbulent models.
Incompressible: Water has a very low compressibility, therefore its been assumed as incompressible.

For the boundary conditions, the velocity was specified at the inlet and zero-gauge pressure was applied at the outlet. No-slip boundary condition was used at all walls.

RESULTS

Figure 4 shows a plot of the flow rate against the frequency of the jet oscillation inside the flow meter for both the experiment and numerical simulation. This plot represents the values recorded in tables 2, 3 and 4 in the appendix. We obtained the frequencies of the different flow rates using Image Processing and Computer Vision Toolbox in MATLAB. [By analyzing the videos, the frequency of oscillation for each flow rate (experimentally and numerically) was obtained.] Results from experimental and numerical methods showed a general trend where the frequency of oscillation increased as the flow rate increased. Furthermore, a linear relationship between the flow rate and frequency of oscillation was observed. This linearity is important, since it suggests that each oscillation cycle corresponds to approximately the same amount of fluid, irrespective of the flow rate.

Figures 5 and 6 (a-c) show three different phases of jet oscillation captured from the experiment and simulation, respectively. The red and blue colors in figure 5 denote the high and low velocities, respectively.

The experimental flow rates were approximately 15% higher than the numerical values at the same frequency. The source of this difference is not known, but may be due (at least in part) to flow rate measurement errors in the experiment.

Table 5 shows the calculated Reynolds numbers for each flow rate at the inlet and outlet. The values are all within the turbulent range for a closed confined flow; however, the CFD simulation uses a laminar model. This type of model might be another source of error as using a suitable turbulent model could produce more accurate results.

CONCLUSION

As seen in this experiment, a jet directed into a converging duct will cause the jet to oscillate at a frequency linearly related to the flow rate. This finding could be beneficial for constructing a flow meter with no moving parts. This meter can also be used as totalizing flow meter. Since the meter has no moving parts to wear over time, it may not require frequent regular re-calibration.

The flow rate–frequency relation shows higher frequencies for the numerical solution than the experimental results. This result may be due to experimental errors.

However, both plots showed approximately linear relationship between flow rate and frequency of oscillation. Improvements in the experimental side include using more accurate experimental flow rate measurement equipment, such as a digital flow meters and ensuring that source of water has a constant flow rate which can reduce experimental errors. The CFD simulation can be improved by adding a suitable turbulence model and testing the effects of mesh-size and time-step reduction, which may lead to more accurate results.

Figure 1. Top View of the model and dimensions

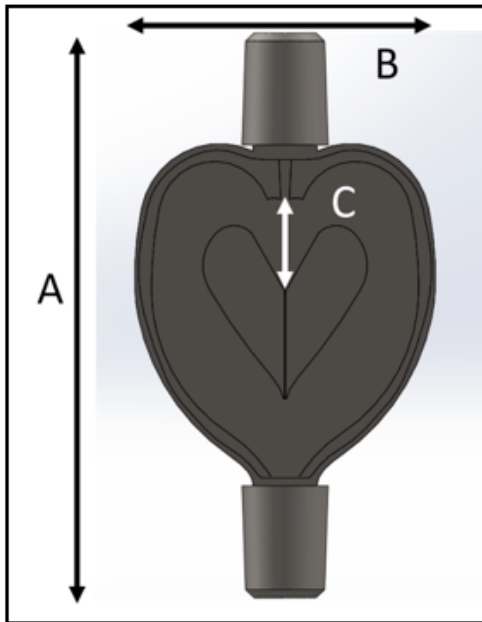

Figure 2. Isometric view of the model

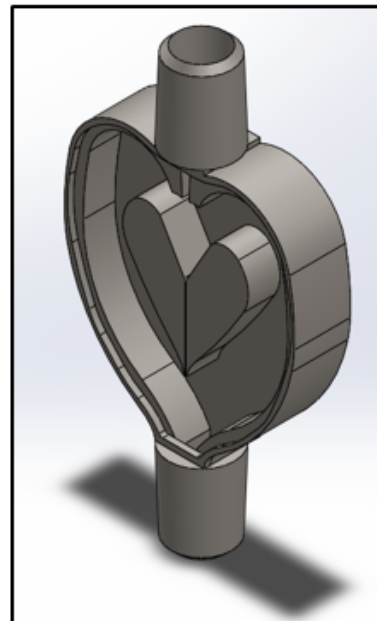

Table 1. Flow meter main dimensions

Dimension	Length (mm)
A	174.1
B	94
C	28.25

Figure 3. Experimental Setup

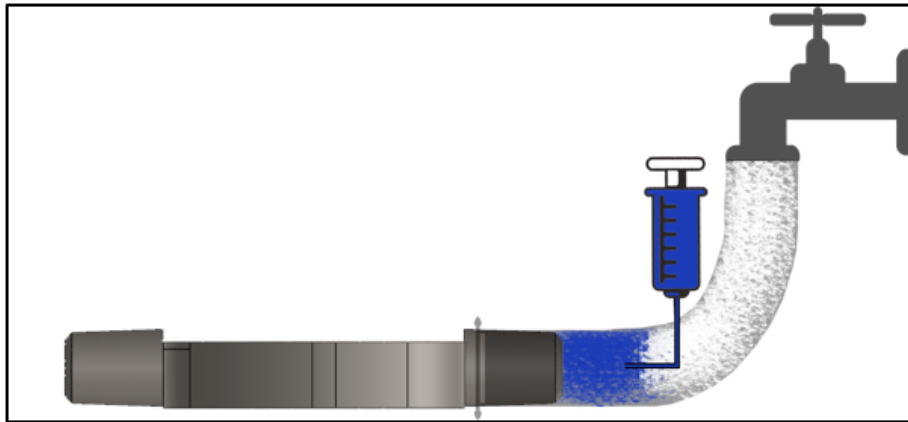

Figure 4. The plot of flow rate versus frequency for both the experimental and simulation results

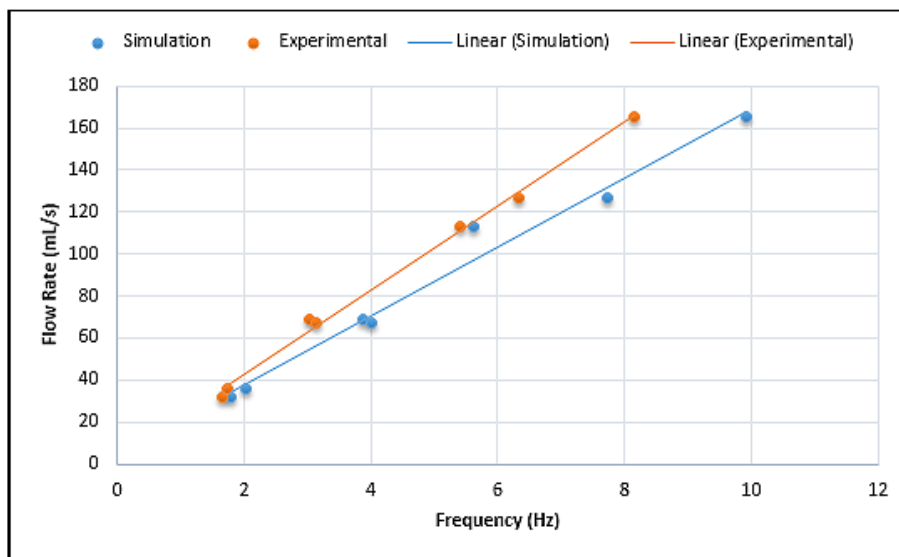

Figure 5. Snapshots of jet oscillation phases from the experiment, cropped and x-rayed from the actual picture in Figure 6

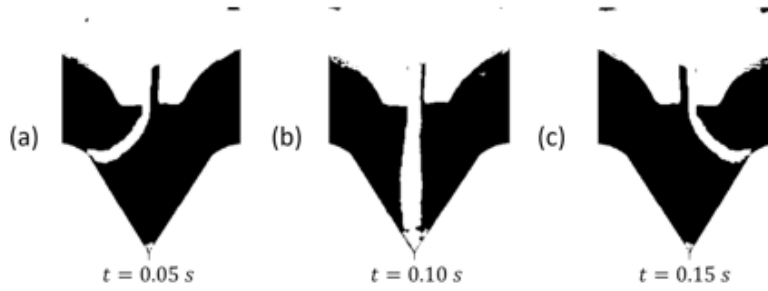

Figure 6. Snapshots of jet oscillation phases from numerical solution simulation

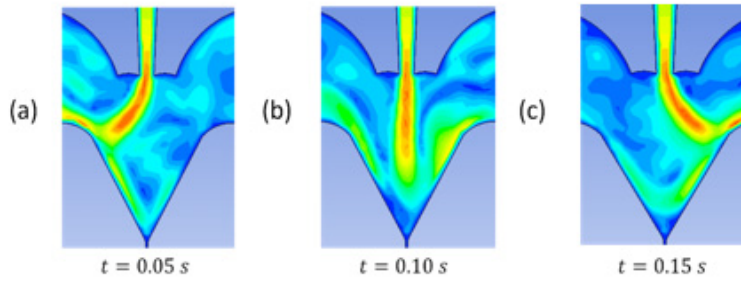

Figure 7. Flow visualization showing the different phases of the jet oscillation in the experiment

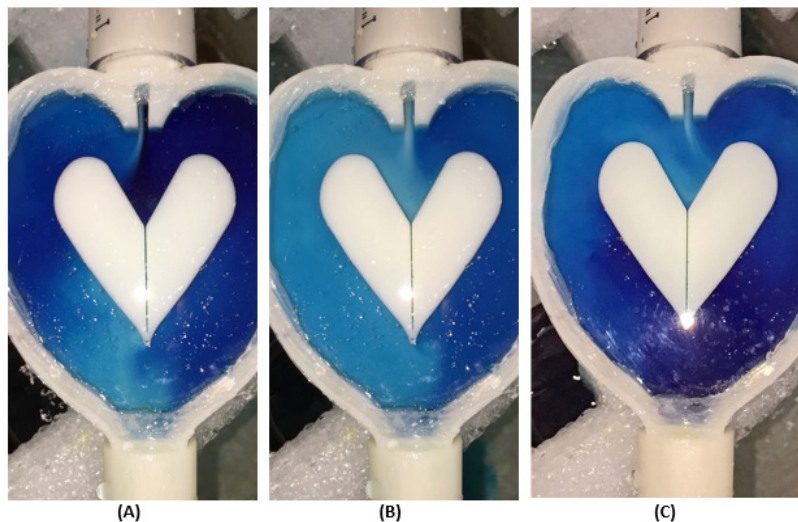

Table 2. Experimental Flow Rate Data recorded for each trial

Trial #	Time (s)	Volume (mL)	Flow Rate (mL/s)	Flow Rate (m ³ /s)
1	5.7	382	67.02	6.702E-05
2	14.12	451	31.94	3.194E-05
3	5.01	345	68.86	6.886E-05
4	2.2	364	165.45	0.00016546
5	2.9	327	112.76	0.0001128
6	2.1	266	126.67	0.0001267
7	9.85	351	35.63	3.563E-05

Table 3. Experimental Frequency of Oscillation Data for each trial

Trial	Frequency (Hz)	Flow Rate (m ³ /s)
#1	3.125	6.7E-05
#2	1.667	3.19E-05
#3	3.041	6.89E-05
#4	8.163	0.000165
#5	5.397	0.000113
#6	6.327	0.000127
#7	1.740	3.56E-05

Table 4. CFD Simulation Frequency of Oscillation Data for each trial

Trial	Frequency (Hz)	Flow Rate (m ³ /s)
#1	4	6.702E-05
#2	1.786	3.194E-05
#3	3.888	6.886E-05
#4	9.9119	0.0001655
#5	5.614	0.00011276
#6	7.732	0.00012667
#7	2.021	3.563E-05

Table 5. Reynold's Number calculation for each flow rate at the Inlet and Outlet

Reynold's Number Calculation		
Nozzle Inlet Cross Section Area		
Area (m ²)	0.0000728	
Effective Diameter (m)	0.007828	
Perimeter (m)	0.0372	
Nozzle Outlet Cross Section Area		
Area (m ²)	0.0000364	
Effective Diameter (m)	0.004608	
Perimeter (m)	0.0316	
Trial	Velocity (m/s)	Re Inlet
#1	0.9206	7171
#2	0.4387	3418
#3	0.9459	7369
#4	2.2727	17705
#5	1.5489	12066
#6	1.7400	13554
#7	0.4895	3813
Trial	Velocity (m/s)	Re Outlet
#1	1.841	8442
#2	0.8775	4023
#3	1.8918	8675
#4	4.5455	20843
#5	3.0978	14204
#6	3.4799	15957
#7	0.9790	4489

REFERENCES

1. Cengel, Yunus. A, and John M. Cimbala. 2006. *Fluid Mechanics Fundamentals and Applications*. New York: McGraw Hill.
2. Mansy, H, and DR. Williams. 1989. "Flow meter based on the trapped vortex pair fluidic oscillator." *Review of Scientific Instruments* 5.
3. Pritchard, Philip J. 2011. *Fox and McDonald's Introduction to Fluid Mechanics*. Wiley.
4. Royle, J.K., and R.F. Boucher. 1972. "Fluidic Flow Measurement and Control Devices." *Measurement and Control* V.