

10-24-2000

Metal and Wood Composite Framing Members for Residential and Light Commercial Construction (DIV A)

Armin Rudd
University of Central Florida

Find similar works at: <https://stars.library.ucf.edu/patents>
University of Central Florida Libraries <http://library.ucf.edu>

This Patent is brought to you for free and open access by the Technology Transfer at STARS. It has been accepted for inclusion in UCF Patents by an authorized administrator of STARS. For more information, please contact STARS@ucf.edu.

Recommended Citation

Rudd, Armin, "Metal and Wood Composite Framing Members for Residential and Light Commercial Construction (DIV A)" (2000). *UCF Patents*. 318.
<https://stars.library.ucf.edu/patents/318>



US006134859A

United States Patent [19]

[11] Patent Number: 6,134,859

Rudd

[45] Date of Patent: Oct. 24, 2000

[54] METAL AND WOOD COMPOSITE FRAMING MEMBERS FOR RESIDENTIAL AND LIGHT COMMERCIAL CONSTRUCTION

4,466,225 8/1984 Hovind 52/730
4,875,316 10/1989 Johnston .
5,072,547 12/1991 DiFazio .
5,285,615 2/1994 Gilmour .
5,440,848 8/1995 Deffet .
5,452,556 9/1995 Taylor .
5,768,849 6/1998 Blazevic 52/737.3

[75] Inventor: Armin F. Rudd, Cocoa, Fla.

[73] Assignee: University of Central Florida, Orlando, Fla.

[21] Appl. No.: 09/332,452

[22] Filed: Jun. 14, 1999

Primary Examiner—Carl D. Friedman
Assistant Examiner—Yvonne M. Horton
Attorney, Agent, or Firm—Brian S. Steinberger; Law Offices of Brian S. Steinberger

Related U.S. Application Data

[62] Division of application No. 08/974,898, Nov. 20, 1997, Pat. No. 5,921,054, which is a division of application No. 08/664,442, Jun. 21, 1996, abandoned.
[60] Provisional application No. 60/012,688, Mar. 1, 1996.

[51] Int. Cl. 7 E04C 3/30

[52] U.S. Cl. 52/737.3; 52/376; 52/730.7; 52/731.8; 52/731.9; 52/738.1; 52/765

[58] Field of Search 52/730.7, 731.1, 52/731.8, 731.9, 737.3, 776, 765, 699, 481.1, 376

References Cited

U.S. PATENT DOCUMENTS

2,851,747 9/1958 Rolen .
3,310,324 3/1967 Boden .
3,531,901 10/1970 Will et al. .
3,960,637 6/1976 Ostrow .
4,031,686 6/1977 Sanford .
4,274,241 6/1981 Lindal .
4,301,635 11/1981 Neufeld .

[57] ABSTRACT

Metal and wood composites are used to create framing members (studs and tracks, joists and bands, rafters, headers and the like.) for lightweight construction. Metal is utilized for its high strength, resistance to rot and insects, cost stability, and potentially lower cost through recycling. Metal that can be used includes roll formed steel approximately 18–22 gauge. Wood is used primarily for its lower thermal conductivity, and availability. The metal components form the primary structure while wood, either solid or other engineered wood, provides some structure and a thermal break. The invention connects J-shaped or triangular shaped metal forms to wood sections. The metal flange ends can have various J, C, L, right triangular, triangular, T and straight line cross-sectional shapes. The wood is fastened to the metal by machine pressing of the metal to wood. Alternatively the fastening includes nails, staples, screws, and the like, and also by adhesive glue. The outward faces of the metal members are preformed with four longitudinal ridges such that the contact surface area to applied sheathings is reduced by about 90%.

3 Claims, 7 Drawing Sheets

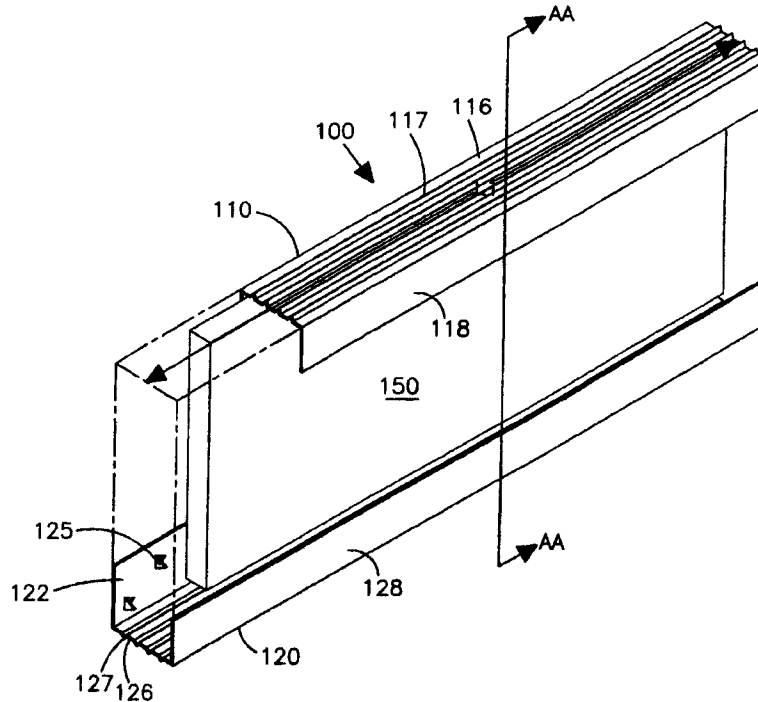

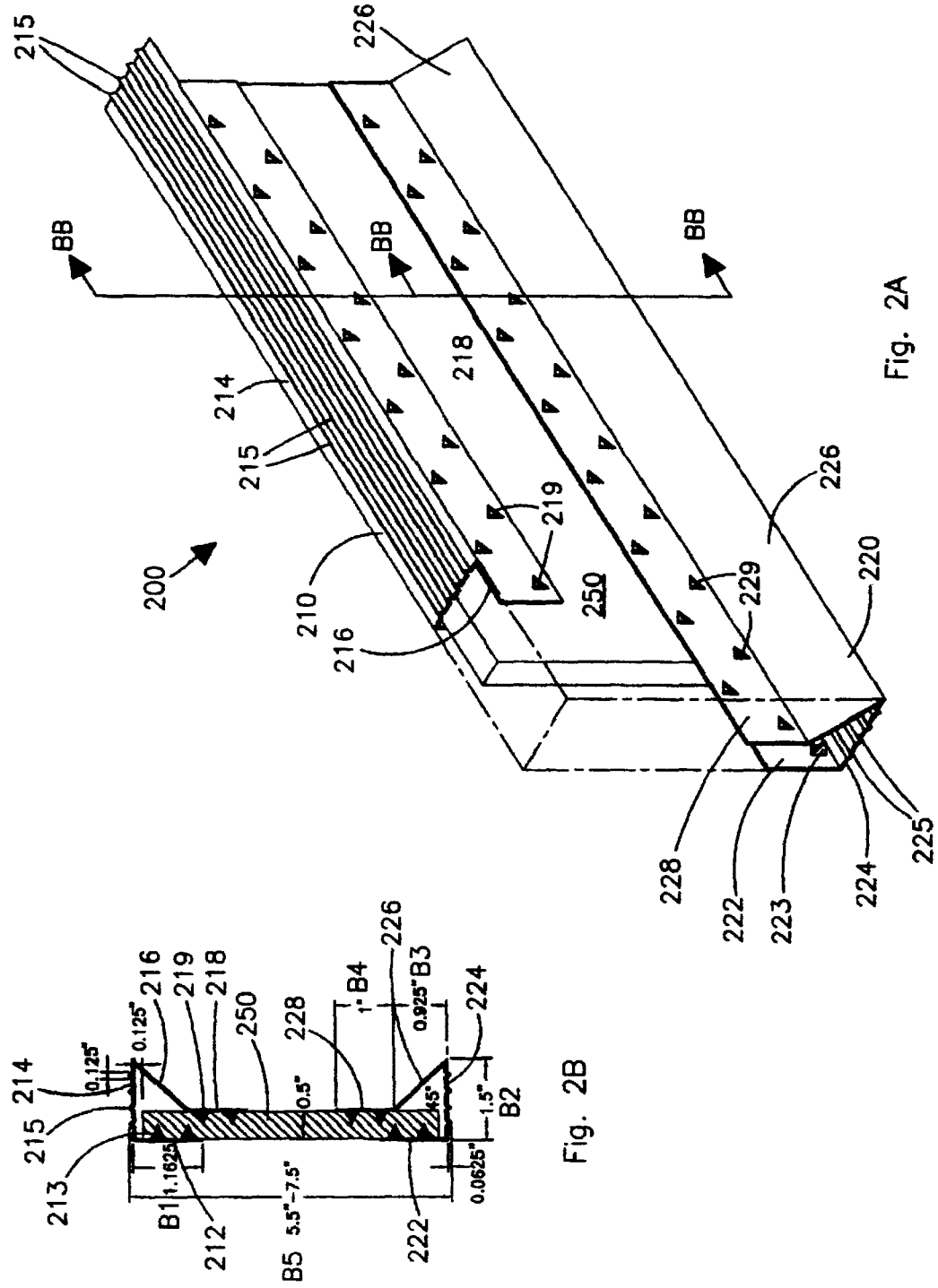

Fig. 2A

Fig. 2B

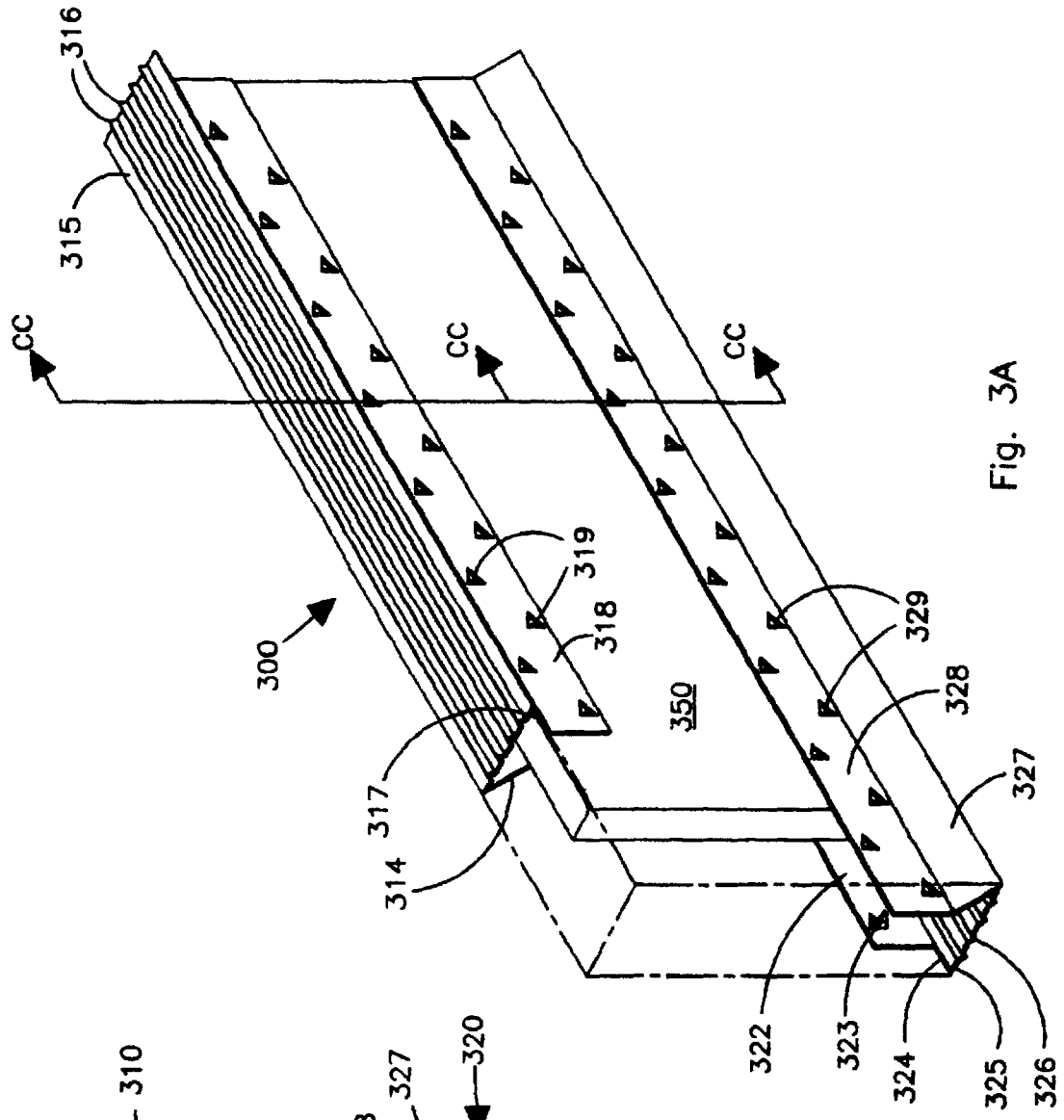

Fig. 3A

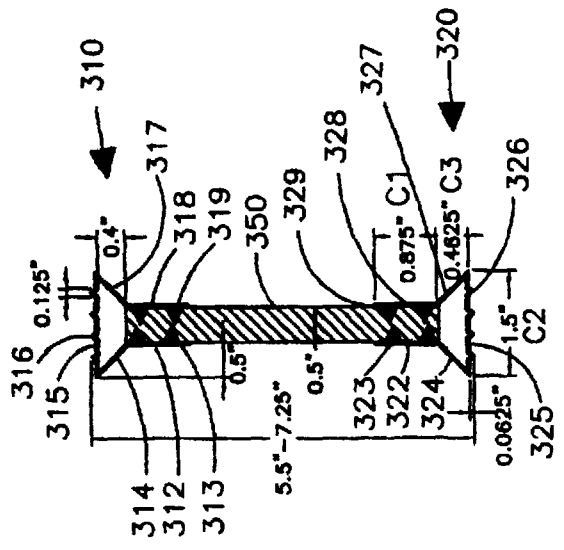

Fig. 3B

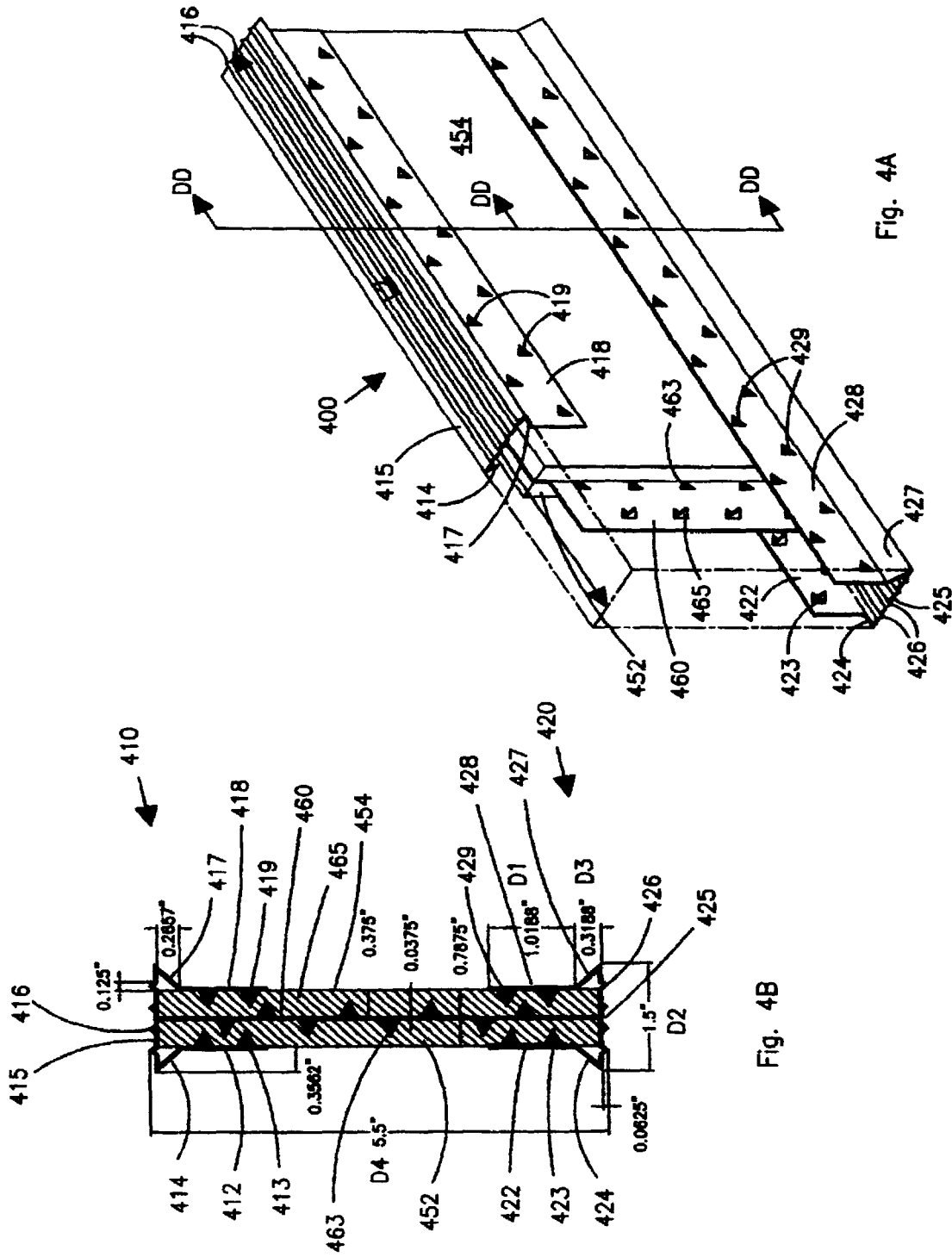

Fig. 4A

Fig. 4B

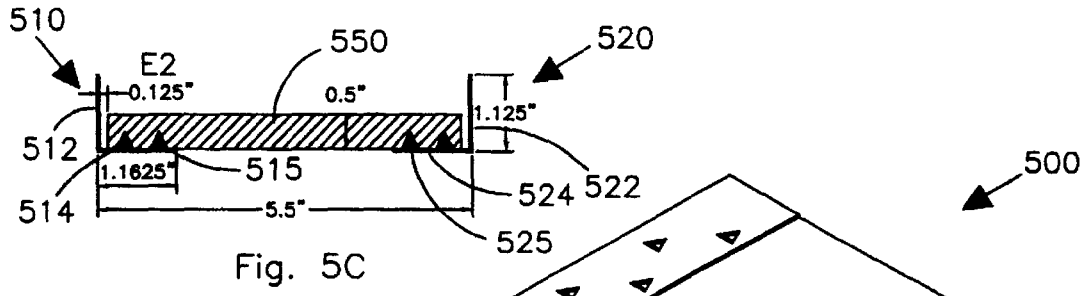

Fig. 5C

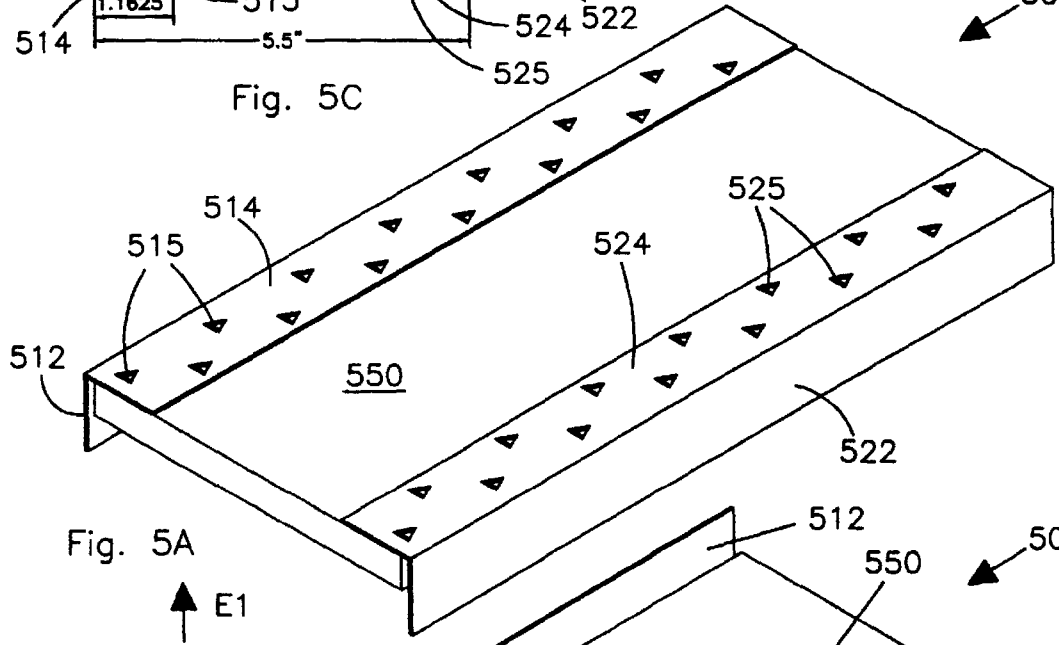

Fig. 5A

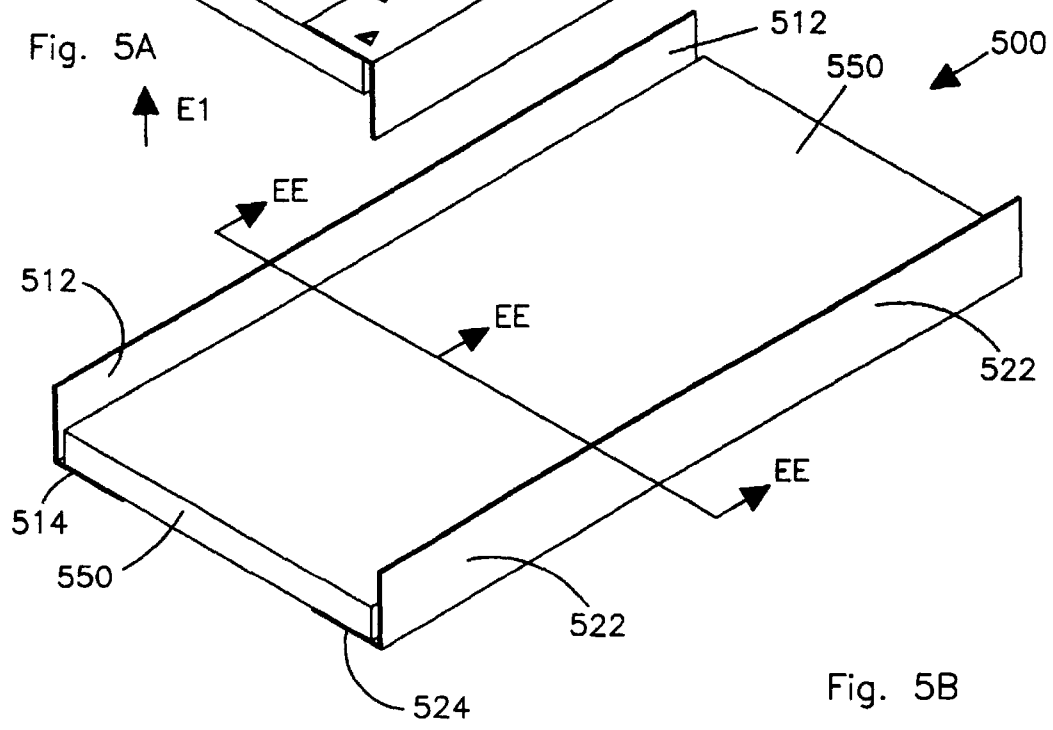

Fig. 5B

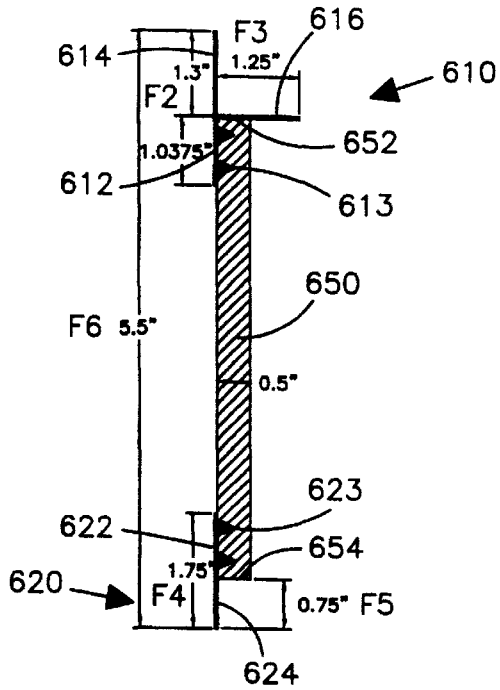

Fig. 6B

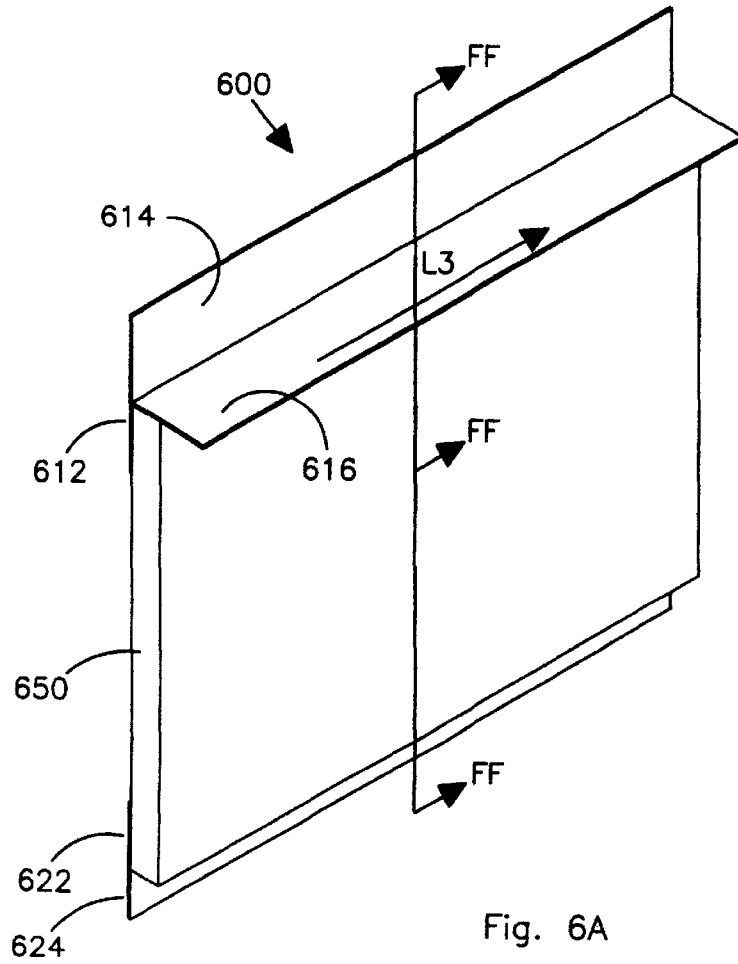

Fig. 6A

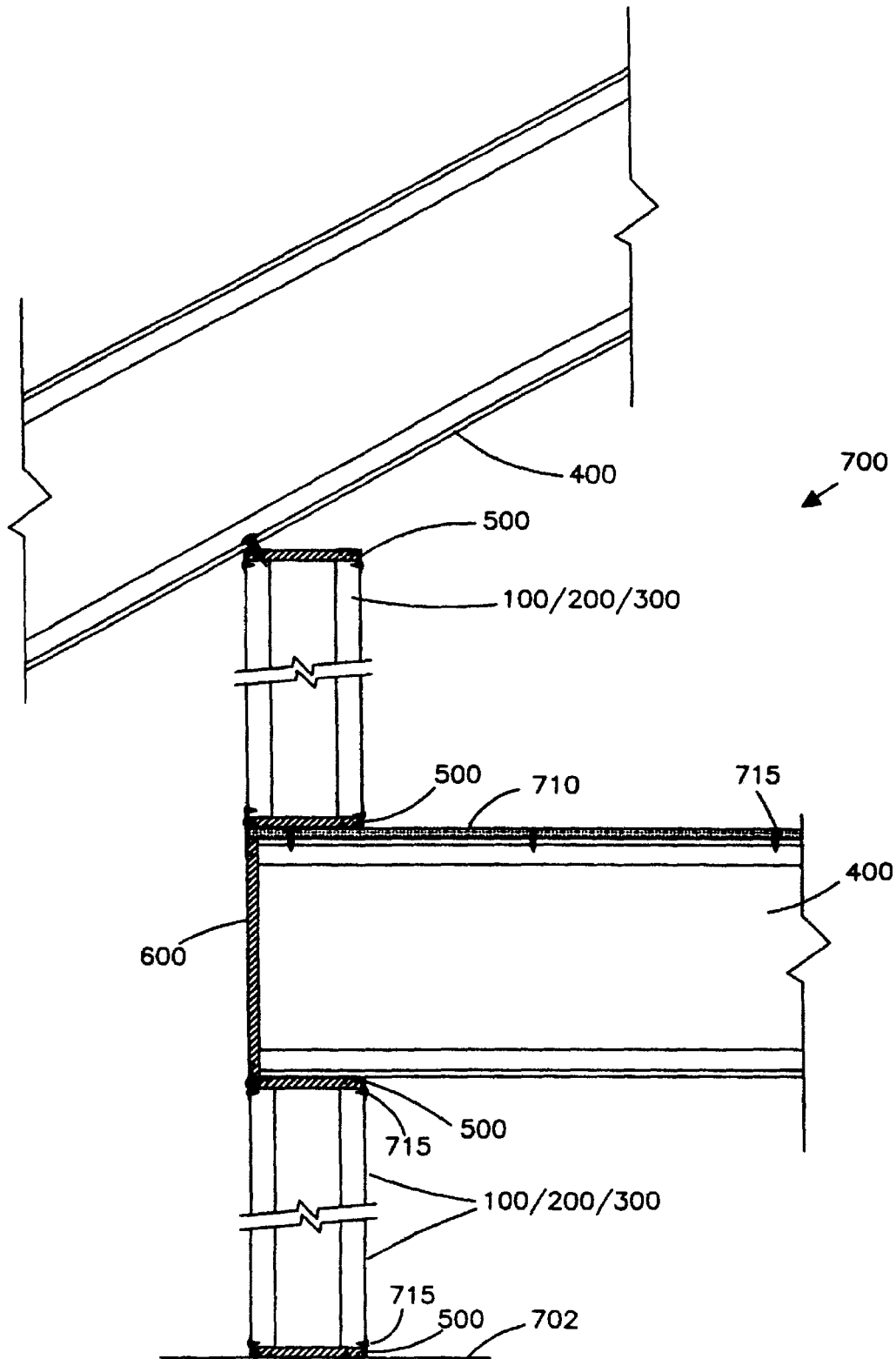

Fig. 7

**METAL AND WOOD COMPOSITE FRAMING
MEMBERS FOR RESIDENTIAL AND LIGHT
COMMERCIAL CONSTRUCTION**

This is a Divisional of application Ser. No. 08/974,898 filed Nov. 20, 1997, now issued as U.S. Pat. No. 5,921,054 on Jul. 13, 1999, which is a Divisional of application Ser. No. 08/664,442 filed Jun. 21, 1996 and now abandoned. This application claims benefit of provisional application No. 60/012,688 Mar. 1, 1996.

This invention relates to composite framing members, more specifically to studs and tracks, joists and bands, headers, and rafters formed from wood and metal composites.

BACKGROUND AND PRIOR ART

Residential and light commercial construction generally use wood as the primary building material for studs, plates, joists, headers and trusses. However, all-wood construction has problems. The rapidly rising cost of raw wood supplies has in effect substantially raised the cost of these members. Further, the quality of available framing lumber continues to decline. Finally, wood is flammable and susceptible to insects and rot.

Due to these problems, many builders have been switching to using all steel framing. The costs between using wood or steel framing is getting closer. In January 1990, the cost of framing lumber was about \$225 per thousand board feet, peaking to highs of \$500 in both January, 1993 and January 1994. Since June 1995, the framing lumber composite price has been rising from \$300 per thousand board feet. Estimates from the AISI and NAHB Research Center state at a framing lumber cost of \$340 to \$385, there would be no difference between the cost of framing a house in steel as compared in wood. Thus, the break-even point between wood and steel framing is at about \$360 per thousand board feet of framing lumber, and the lumber price has exceeded that point several times in recent years by as much as 40%, giving steel a competitive advantage.

Recycling has additionally helped the cost of steel to remain on a stable or downward trend. Steel costs have varied little in recent years. Traditionally variations can be correlated to steel demand by the automobile industry when demand is high, steel usually increases slightly in price. Consequently, the use of metal framing in residential and light commercial construction is increasing, a trend recognized and encouraged by the American Iron and Steel Institute (AISI).

All steel studs, tracks and trusses are being manufactured by Tri-Chord, HL Stud Corporation, Truswall Systems, Techbuilt Manufacturing, Knudson Manufacturing, John McDonald, and MiTek Ultra-Span Systems.

A problem with using all steel framing is its high thermal conductivity, leading to thermal bridging, "ghosting", and greater potential for water vapor condensation on interior wall surfaces. "Ghosting" is when an unsightly streak of dust accumulates on the interior wallboard, where the steel studs lie behind, due to an acceleration of dust particles toward the colder surface. Another problem of using all steel framing is the increased energy use for space conditioning (heating and cooling). Metal used for exterior framing members allows greater conduction heat transfer between the outside and inside surfaces of a wall, roof or floor. In colder climates, this increased conduction can cause condensation in interior surfaces, contributing to material degradation and mold and mildew growth. Metal framing also decreases the effective-

ness of insulation installed in the cavity between the metal framing due to increased three dimensional thermal shorting effects. Higher sound transmission is another disadvantage of metal framing since sound conductivity is greater in metal than in wood. Electricians have more difficulty working with all steel framing when running holes for wiring since metal is more difficult to drill than wood, and grommets or conduits must be used to protect the wire.

U.S. Pat. No. 5,285,615 to Gilmour describes a thermal metallic building stud. However, the Gilmour member is entirely formed from metal. In Gilmour, the thermal conductivity is only partially reduced by having raised dimples on the ends contacting other building materials.

U.S. Pat. No. 3,960,637 to Ostrow describes impractical wood and metal composites. Ostrow requires each end flange have tapered channels, the end flanges being formed from extruded aluminum, molded plastic and fiberglass. Ends of the vertical wood web must be fit and pressed into a tapered channel. Besides the difficulty of aligning these parts together, other inherent problems exist. Extruding the channel flanges from aluminum or using molds, cuts and rolling to create the channelled plastic and fiberglass end flanges is expensive to manufacture. To stabilize the structures, Ostrow describes additional labor and manufacturing costs of gluing members together and sandwiching mounting blocks on the outsides of each channel.

Other metal and wood framing member patents of related but less significant interest include: U.S. Pat. No. 5,452,556 to Taylor; 5,440,848 to Deffet; 5,072,547 to DiFazio; 4,875,316 to Johnston; 4,301,635 to Neufeld; 4,274,241 to Lindal; 4,031,686 to Sanford; and 3,531,901 to Meechan.

SUMMARY OF THE INVENTION

The first objective of the present invention is to provide a metal/wood composite wall stud that increases the total thermal resistance of a typical steel framed insulated wall section by some 43 percent and would eliminate interior condensation and "ghosting" for all but the coldest regions of the United States.

The second object of this invention is to provide a wood and metal composite framing combinations that achieve a resource efficient and economic construction framing member. Metal is used for its high strength, and potentially lower cost and resource efficiency through recycling. Wood is used primarily for its lower thermal conductivity and for its availability as a renewable resource, and for its workability.

The third object of this invention is to provide a wood and metal composite framing members that allows electricians to be able to route wires through walls in the same way they are accustomed to doing with solid framing lumber.

The fourth object of this invention is to provide a wood and metal composite framing member that would be easy to manufacture.

The fifth object of this invention is to provide a wood and metal composite framing member that has low sound conductivity compared to prior art steel framing members.

The sixth object of this invention is to provide a wood and metal composite framing member that has reduced effects from flammability compared to all wood members.

The invention includes J-shaped, L-shaped, triangular shaped cross-sectional metal forms connected by a wood midsections, whereby the wood is fastened to the metal by machine pressing of the metal to wood, similar to the common truss plate, or by nails, staples, screws, or other mechanical fastening means, or by adhesive glue. The

outward faces of the metal members are pre-formed with four longitudinal ridges such that the contact surface area to applied sheathings is reduced by about 90%.

Metal and wood composites are used to create framing members (studs and tracks, joists and bands, headers, rafters, and the like) for light-weight construction. Metal is utilized for its high strength, resistance to rot and insects, cost stability, and potentially lower cost through recycling. Wood is used primarily for its lower thermal conductivity, and availability. The metal components form the primary structure while wood, either solid or other engineered wood, provides some structure and a thermal break.

Metal/wood composite framing members can be used in place of conventional wood framing members such as: 2x4 and 2x6 wall studs, and 2x8, 2x10, 2x12 and other dimensions of roof rafters, floor joists and headers. The novel framing members can be used to replace conventional light-gauge steel framing to reduce thermal transmittance and sound transmission.

Further objects and advantages of this invention will be apparent from the following detailed description of a presently preferred embodiment which is illustrated schematically in the accompanying drawings.

BRIEF DESCRIPTION OF THE FIGURES

FIG. 1A is a perspective isometric view of a first preferred embodiment metal/wood stud.

FIG. 1B is a cross-sectional view of the embodiment of FIG. 1A along arrow AA.

FIG. 2A is a perspective isometric view of a second preferred embodiment metal/wood stud.

FIG. 2B is a cross-sectional view of the embodiment of FIG. 2A along arrow BB.

FIG. 3A is a perspective isometric view of a third preferred embodiment metal/wood stud.

FIG. 3B is a cross-sectional view of the embodiment of FIG. 3A along arrow CC.

FIG. 4A is a perspective isometric view of a fourth preferred embodiment metal/wood joist, rafter and header.

FIG. 4B is a cross-sectional view of the embodiment of FIG. 4A along arrow DD.

FIG. 5A is a top perspective view of a fifth embodiment track for metal/wood stud systems.

FIG. 5B is a bottom perspective view of the embodiment of FIG. 5A along arrow EE.

FIG. 5C is a cross-sectional view of the embodiment of FIG. 5B along arrow EE.

FIG. 6A is a perspective view of a sixth preferred embodiment metal/wood band.

FIG. 6B is a cross-sectional view of the embodiment of FIG. 6A along arrow FF.

FIG. 7 is a cross-sectional view a framing system utilizing the embodiments of FIGS. 1A-6B.

DESCRIPTION OF THE PREFERRED EMBODIMENT

Before explaining the disclosed embodiment of the present invention in detail it is to be understood that the invention is not limited in its application to the details of the particular arrangement shown since the invention is capable of other embodiments. Also, the terminology used herein is for the purpose of description and not of limitation.

The preferred method of calculating thermal transmittance for building assemblies with integral steel is the zone

method published by the American Society of Heating Refrigeration and Air-Conditioning Engineers (ASHRAE). A recent study by the National Association of Home Builders Research Center and Oak Ridge National Laboratory verified the usefulness of the zone method for calculating thermal transmittance for light gauge steel walls.

Thermal transmittance calculations were completed using the zone method for the metal/wood stud invention embodiments. Table 1 shows a comparison of thermal transmittance given as total R-value) for nine wall configurations. The first wall listed is a conventional 2x4 wood frame wall with 1/2" plywood sheathing and R-11 fiberglass cavity insulation. The total wall R-value is 13.2 hr-F-ft²/Btu. the second and third walls listed are conventional metal stud walls, one with 1/2" plywood sheathing (R-7.9) and the other with 1/2" extruded polystyrene sheathing (R-11.4). With conventional metal studs, high resistivity insulated sheathing is necessary to limit the large loss of total thermal resistance when low resistivity sheathings are used. In some cases, it is not desirable to use the non-structural insulated sheathing, such as when brick ties are needed, or when higher racking resistance is needed.

In comparison, the metal/wood stud walls corresponding to those described in the subject invention has a 43 per cent greater total R-value a the conventional metal stud wall when using plywood sheathing. Thermal performance of the metal/wood stud wall with plywood sheathing is nearly the same as the conventional wall with 1/2" extruded polystyrene (XPS insulated sheathing). Where non-structural sheathing is acceptable, fiber board sheathing, which is much less expensive than plywood, further increases the total R-value of the metal/wood stud wall.

TABLE 1

COMPARISON OF THERMAL TRANSMITTANCE FOR CONVENTIONAL METAL STUD WALL AND NOVEL METAL/WOOD STUD WALL

Description	Stud Size Inch	Stud Spacing Inch O.C.	Cavity Insula- tion	Exterior Sheathing	Total R- Value
1. Conventional metal stud,*	1.625 x 3.625	24	R-11	1/2" plywood	7.9
2. Conventional metal stud,*	1.625 x 3.625	24	R-11	1/2" XPS	11.4
3. Novel metal/wood stud,	1.5 x 3.5	24	R-11	1/2" plywood	11.3
4. Novel metal/wood stud	1.5 x 3.5	24	R-13	1/2" plywood	12.8
5. Novel metal/wood stud	1.5 x 3.5	24	R-15	1/2" plywood	14.2
6. Novel metal/wood stud	1.5 x 3.5	24	R-11	1/2" fiber board	12.1
7. Novel metal/wood stud	1.5 x 3.5	24	R-13	1/2" fiber board	13.6
8. Novel metal/wood stud	1.5 x 3.5	24	R-15	1/2" fiber board	15.0

*Conventional metal stud values from "Thermodesign Guide for Exterior Walls, American Iron and Steel Institute, Washington, D.C., Pub. No. RG-9405, Jan. 1995. Comparison of vertical, transverse, and racking load capacities of 2 x 4 wood stud, metal stud, and subject invention wood/metal composite stud. Structural analysis by Kim McLeod, P.E. of Key-mark Enterprises, Boulder, Colorado.

Summary calculation results compared the allowable axial load for stud elements subjected to combined loading with axial and bending component. The three elements analyzed were a conventional 2x4 wood, a conventional 20

gauge steel stud, and the present invention metal/wood composite stud. All elements were 8' tall, and spaced 16" O.C. Wind (transverse) load at 110 mph. Table 2 shows that the metal/wood composite section can support 54% more than the metal stud, and 250% more weight than the wood stud. This gives the opportunity for further cost optimization by increasing the spacing which would reduce the number of studs required, or for reducing the amount of steel used in the composite section.

TABLE 2

STRUCTURAL CALCULATION RESULTS FOR METAL/WOOD STUD			
	2 x 4 Wood Stud	3.5" 20 Gauge Metal Stud	3.5" Metal/Wood Composite Section
Allowable Axial Load 8' tall stud 16" O.C. 110 mph wind	551 lb	894 lb	1378 lb

FIG. 1A is a perspective isometric view of a first preferred embodiment metal/wood stud **100**. FIG. 1B is a cross-sectional view of the embodiment **100** of FIG. 1A along arrow AA. Referring to FIGS. 1A-1B, embodiment **100** includes metal forms **110**, **120** such as but not limited to 20 gauge steel has been cold-formed in a roll press into a cross-sectional channel J-shape. Each form **110**, **120** includes steel web portions **112**, **122** that have staggered rows of cut-out portions **115**, **125** which are of a pressed tooth type triangular shape. Web portions **112**, **122** are perpendicular to flanges **116**, **126** which include approximately 4 rows of raised V-shaped grooves **117**, **127** running longitudinally along the exterior of the flanges **116**, **126**. Flange returns **118**, **128** are perpendicular to flanges **116**, **126**. Teeth **115**, **125** can be hydraulically pressed adjacent the top and bottom rear side **152** of central web board **150**. Central web board **150** can be solid wood, OSB, (oriented strand board) plywood and the like, having a thickness of approximately ½ an inch. Alternatively, web portions **112**, **122** of forms **110**, **120** can be fastened to the central web board **150** by nails, screws, staples and the like, or adhesively glued. A finished metal/wood stud **100** can have a length, L1, of approximately 8 feet or longer, height H1 of approximately 3.5 to 5.5 inches, width W1 of approximately 1.5 inches. Web portions **112**, **122** can have a height, h1 of approximately 1.125 inches, front plate height, h2 of approximately 0.75 inches, raised grooves R1, of approximately 0.125 inches. A spacing, x1 of approximately 0.125 inches separates each flange **116**, **126** from the top and bottom of central web board **150**.

FIG. 2A is a perspective view of a second preferred embodiment metal/wood stud **200**. FIG. 2B is a cross-sectional view of the embodiment **200** of FIG. 2A along arrow BB. Referring to FIGS. 2A-2B, embodiment **200** includes metal forms **210**, **220** such as but not limited to 20 gauge steel that has been roll pressed into a cross-sectional channel right-triangular-shape. Each form **210**, **220** includes outer web portions **212**, **222** that have staggered rows of cut-out portions **213**, **223** which are of a pressed tooth type triangular shape. Outer web portions **212**, **222** are perpendicular to flanges **214**, **224** which include approximately 4 rows of raised V-shaped grooves **215**, **225** running longitudinally along their exterior surface. Flange returns **216**, **226** are approximately 45 degrees to flanges **214**, **224**, and are connected to inner web portions **218**, **228** each having

staggered rows of cut-out portions **219**, **229** which also are of the pressed tooth type triangular shape. Teeth **213**, **219** and **223**, **229** can be firmly pressed adjacent the top and bottom of central web board **250**. Central web board **250** can be solid wood, OSB, plywood and the like, having a thickness of approximately ½ an inch. Alternatively, web portions **212**, **218**, **222**, **228** can be fastened to the central web board **250** by nails, screws, staples and the like. Outer web portions **212**, **222** can have a height, B1 of approximately 1.1625 inches, flanges **214**, **224** can have a width, B2 of approximately 1.5 inches, flange returns **216**, **226** can have a height, B3 of approximately 0.925 inches and inner web portions **218**, **228** can have a height, B4 of approximately 1 inch. A finished metal/wood stud **200** can have the remaining dimensions and spacings similar to the embodiment **100** previously described, except height, B5 can be approximately 5.5 to approximately 7.25 inches.

FIG. 3A is a perspective isometric view of a third preferred embodiment metal/wood stud **300**. FIG. 3B is a cross-sectional view of the embodiment **300** of FIG. 3A along arrow CC. Referring to FIGS. 3A-3B, embodiment **300** includes metal forms **310**, **320** such as but not limited to 20 gauge steel has been roll pressed into a cross-sectional channel triangular-shape with parallel plates on the apex of the triangle. Each form **310**, **320** includes metal web portions **312**, **322**, **318**, **328** that have staggered rows of cutout portions **313**, **323**, **319**, **329** which are of a pressed tooth type triangular shape. Web portions **312**, **322**, **318**, **328** attach to 45 degree flange returns **314**, **324** which are attached to respective flanges **315**, **325** which include approximately 4 rows of raised V-shaped grooves **316**, **326** running longitudinally along their exterior surface. Teeth **313**, **319** and **323**, **329** can be pressed adjacent the top and bottom of central web board **350**. Central web board **350** can be solid wood, OSB, plywood and the like, having a thickness of approximately ½ an inch. Alternatively, metal web portions **312**, **318**, **322**, **328** can be fastened to the central web board **350** by nails, screws, staples and the like. Metal web portions **312**, **318**, **322**, **328** can have a height, C1 of approximately 0.875 inches, flanges **315**, **325** can have a width, C2 of approximately 1.5 inches, flange returns **314**, **317**, **324**, **327** can have a height, C3 of approximately 0.4625 inches. A finished metal/wood stud **300** can have remaining dimensions and spacings similar to the embodiment **200** previously described.

FIG. 4A is a perspective isometric view of a fourth preferred embodiment **400** useful as a metal/wood joist, rafter and header. FIG. 4B is a cross-sectional view of the embodiment **400** of FIG. 4A along arrow DD. Referring to FIGS. 4A-4B, embodiment **400** includes metal forms **410**, **420** such as but not limited to 20 gauge steel has been roll pressed into a cross-sectional channel triangular-shape with parallel plates on the apex of the triangle. Each form **410**, **420** includes metal web portions **412**, **422**, **418**, **428** that have staggered rows of cut-out portions **413**, **423**, **419**, **429** which are of a pressed tooth type triangular shape. Metal web portions **412**, **422**, **418**, **428** attach to 45 degree flange returns **414**, **424**, **417**, **427** which are attached to respective flanges **415**, **425** which include approximately 4 rows of raised V-shaped grooves **416**, **426** running longitudinally along their exterior surface. Teeth **413**, **419** and **423**, **429** can be pressed adjacent the top and bottom portions of central web boards **452**, **454**. A central metal plate **460** has left facing tooth rows **463** and right facing tooth rows **465** for connecting to adjacent respective web boards **452**, **454**. Plate **460** has a spacing above and below to separate such from flanges **415**, **425**. Central web boards **452**, **454** can be solid

wood, OSB, plywood and the like, having a thickness of approximately 0.375 inches. Alternatively, metal web portions **412**, **418**, **422**, **428** can be fastened to the central web boards **452**, **454** by nails, screws, staples and the like. Metal web portions **412**, **418**, **422**, **428** can have a height, **D1** of approximately 1.0188 inches, flanges **415**, **425** can have a width, **D2** of approximately 1.5 inches, flange returns **414**, **417**, **424**, **427** can have a height, **D3** of approximately 0.3188 inches. A finished embodiment **400** can have practically any length, **L2** to serve as a floor joist, rafter or header, width **D2** can be approximately 1.5 inches and height **D4**, can be approximately 5.5 inches or more.

FIG. 5A is a top perspective view of a fifth embodiment track **500** for metal/wood stud and track systems. FIG. 5B is a bottom perspective view of the embodiment **500** of FIG. 5A along arrow E1. FIG. 5C is a cross-sectional view of the embodiment **500** of FIG. 5B along arrow EE. Referring to FIGS. 5A–5C, embodiment **500** includes metal forms **510**, **520** each having a generally L-shaped cross-section. Forms **510**, **520** each include flanges **512**, **522** approximately 1.125 inches in height perpendicular to metal web portions **514**, **524**, which are approximately 1.1625 inches in length. Metal web portions **514**, **524** have tooth shaped triangular cut-outs **515**, **525**, which are pressed into sides of center-web-board **550**. A spacing **E2** of approximately 0.125 inches separates the ends of center-web-board **550** from flanges **512**, **522**, respectively. A finished embodiment **500** can have remaining dimensions and spacings similar to the embodiments **100**, **200**, and **300** above.

FIG. 6A is a perspective view of a sixth preferred embodiment metal/wood joists and bands **600**. FIG. 6B is a cross-sectional view of the embodiment **600** of FIG. 6A along arrow FF.

Referring to FIGS. 6A–6B, embodiment **600** includes top metal form **610** having a T-cross-sectional shape and lower metal form **620** having a straight line cross-sectional shape. Form **610** includes metal web portion **612**, having a length, **F1** of approximately 1.0375 inches having tooth shaped triangular cut-outs **613** which are pressed into upper end sides of wood center web board **650**. Form **610** further includes an upright leg **614** having a length **F2** of approximately 1.3 inches, perpendicular to a third leg **616**, having a length, **F3** of approximately 1.25 inches, which abuts against and overlaps top end **652** of centerboard **650**. Lower metal form **620** has a metal web portion **622** having tooth shaped triangular cut-outs **623** which are pressed into upper end sides of wood center board **650**, and a continuous extended plate **624**. The continuous width **F4**, of metal plate **622**, **624** is approximately 1.75 inches, with plate **624** extending a length **F5** of approximately 0.75 inches from the lower end **654** of center-web-board **650** having thickness of approximately 0.5 inches. A finished embodiment **600** can have a width **F6** and length **L3** similar to embodiment **400**.

FIG. 7 is a cross-sectional view a framing system **700** utilizing the embodiments of FIGS. 1A–6B. Embodiment **700** can be a two story building having a metal/wood bottom track **500** attached at floor **702** by conventional fasteners such as nails, screws, bolts and the like. Vertically oriented metal/wood studs **100/200/300** can be attached to floor and ceiling tracks **500** by steel framing screws **715** and the like. A metal/wood band **600** attaches first floor ceiling track **500** to metal/wood floor joist **400** and subfloor **710**, which has conventional steel framing flathead type screws **716** and the like. The second floor has a similar arrangement with rafters **400** attached at conventional angles to upper metal/wood top track **500**.

A cost of a metal/wood composite stud such as those described in the previous embodiment **100** is estimated to be

\$4.24. The lowest cost of conventional 20 gauge steel studs is \$2.52 each, however, to obtain the same thermal performance, an insulated sheathing is required which raises the cost to \$4.55 per stud. The metal/wood framing member's invention is directly cost effective compared to the conventional metal stud. In addition, structural calculations show that the metal/wood stud configuration can support 54% more weight at the same 8' wall height, 16" O.C. spacing, and 110 mph wind load. This give opportunity for further cost optimization by increasing the spacing which would reduce the number of studs required. For example, a 2000 square foot house framed 16" O.C. will have about 168 conventional steel exterior wall studs, the same house framed 24" O.C. with the stronger metal/wood composite exterior wall studs will use only 107 studs. With 61 fewer exterior wall studs required, the builder can save about \$270.

While the invention has been described, disclosed, illustrated and shown in various terms of certain embodiments or modifications which it has presumed in practice, the scope of the invention is not intended to be, nor should it be deemed to be, limited thereby and such other modifications or embodiments as may be suggested by the teachings herein are particularly reserved especially as they fall within the breadth and scope of the claims here appended. For the claims, the invention will be described as having all metal portions including the forms to be referred to as flanges, and all mid wood portions will be referred to as wood web members.

What is claimed is:

1. A stud support member formed from mixed composite materials which are used for residential and light commercial construction, the stud support member comprises in combination:

a substantially vertically elongated web member having a first longitudinal side, a second longitudinal side opposite the first longitudinal side, a first short end and a second short end opposite the first short end, a first face and a second face opposite the first face, the web member formed from a first material;

a first J-shaped form connected to the first longitudinal side of the web member, the first J-shaped form having a flange spaced apart from the first longitudinal side of the web member and a first interior facing flange return connected to the flange, the first J-shaped form having a web portion adapted to connect the flange to the first face of the web member;

a second J-shaped form connected to the second longitudinal side of the web member and a second interior facing flange return connected to the flange, the first interior facing flange return and the second interior facing flange return being over the first face of the elongated web member, the second J-shaped form having a flange spaced apart from the second longitudinal side of the web member, the second J-shaped form having a web portion adapted to connect the flange to the first face of the web member, the first J-shaped form and the second J-shaped form being formed from a second material, so that the first material and the second material are dissimilar from one another, thereby increasing the thermal resistance, and axial load capability and reducing interior condensation and ghosting.

2. The stud support member of claim 1, wherein the flange on the first J-shaped form, and the flange on the second J-shaped form each include:

parallel rows of V-shaped ridges.

3. A stud support member formed from mixed composite materials which are used for residential and light commercial construction, the stud support member comprises in combination:

a substantially vertically elongated web member having a first longitudinal side, second longitudinal side opposite the first longitudinal side, a first short end and a second short end opposite the first short end, a first face and a second face opposite the first face, the web member formed from a first material;

a first J-shaped form connected to the first longitudinal side of the web member, the first J-shaped form having a flange spaced apart from the first longitudinal side of the web member and a second interior facing flange return connected to the flange, the first J-shaped form having a web portion adapted to connect the flange to the first face of the web member, the first J-shaped form having a return portion connected to the flange;

a second J-shaped form connected to the second longitudinal side of the web member, the second J-shaped form having a flange spaced apart from the second longitudinal side of the web member and a second interior facing flange return connected to the flange, the first interior facing flange return and the second interior facing flange return being over the first face of the elongated web member, the second J-shaped form having a web portion adapted to connect the flange to the first face of the web member, the second J-shaped form having a return portion connected to the flange, the first J-shaped form and the second J-shaped form being formed from a second material, so that the first material and the second material are dissimilar from one another, thereby increasing the thermal resistance, and axial load capability and reducing interior condensation and ghosting.

* * * * *