

FLORIDA SOLAR



ENERGY CENTER®

Designing and Installing Radiant Barrier Systems

Author

Fairey, Philip.

Publication Number

FSEC-DN-7-84

Copyright

Copyright © Florida Solar Energy Center/University of Central Florida
1679 Clearlake Road, Cocoa, Florida 32922, USA
(321) 638-1000
All rights reserved.

Disclaimer

The Florida Solar Energy Center/University of Central Florida nor any agency thereof, nor any of their employees, makes any warranty, express or implied, or assumes any legal liability or responsibility for the accuracy, completeness, or usefulness of any information, apparatus, product, or process disclosed, or represents that its use would not infringe privately owned rights. Reference herein to any specific commercial product, process, or service by trade name, trademark, manufacturer, or otherwise does not necessarily constitute or imply its endorsement, recommendation, or favoring by the Florida Solar Energy Center/University of Central Florida or any agency thereof. The views and opinions of authors expressed herein do not necessarily state or reflect those of the Florida Solar Energy Center/University of Central Florida or any agency thereof.



Designing and installing radiant barrier systems

Philip Fairey
Principal Research Scientist

Florida Solar Energy Center

Introduction

A radiant barrier system is, in general, a layer of foil facing an airspace, installed in the envelope of a building. Such systems are very effective in impeding radiant heat transfer and consequent heat gain, especially in southern residences.

Before designing and installing a radiant barrier system, you should become familiar with the concept of radiant energy transfer. Design Note 6, *Radiant Energy Transfer and Radiant Barrier Systems in Buildings*, is required reading if you are not familiar with this concept. It is available free from the Florida Solar Energy Center, Public Information Office, 300 State Road 401, Cape Canaveral, FL 32920.

Assuming that you have an understanding of radiant energy transfer and how radiant barriers work in buildings, this publication presents a series of construction alternatives. You can adjust most of the details to suit your project as long as you don't violate the principles presented here and in Design Note 6.

Roof systems

Most roof types already contain some kind of attic or airspace that can accommodate an effective radiant barrier system. In new construction it should be easy to install radiant barrier systems regardless of roof pitch. Figure 1 shows three possible generic locations for radiant barriers in attics. When first installed, there will be no significant difference in the effectiveness of these locations. But in time, location 3 will suffer because of dust accumulation, which decreases performance. Dust can't collect on the underside of the radiant barriers at locations 1 or 2.

Location 2 is best for two reasons. First, it can easily have two radiant barrier surfaces (top and bottom). Second — and more important — it offers the potential for separately ventilating the space between the radiant barrier and hot roof deck and the attic space itself. This results in an attic air temperature somewhat closer to the conditioned space temperature in both winter and summer. As with location 3, dust may collect on the top of location 2, but a radiant barrier surface facing downward will perform as well as one facing upward. Therefore, for reasons of dust accumulation, use location 1 or 2 and depend on the down side for radiation control.

In new construction, another alternative may offer the advantages of location 2 and the construction ease of location 1. This construction places the radiant barrier on top of the roof rafters (or trusses) before the roof decking is applied. It is installed so that it droops $1\frac{1}{2}$ " to 2" below the upper surface of the roof structure. When the roof decking is applied, an airspace separates it from the radiant barrier in a way similar to that of location 2. This airspace also can be vented separately from the attic. As with location 2 the most reflective radiant barrier surface should face downward toward the attic airspace.

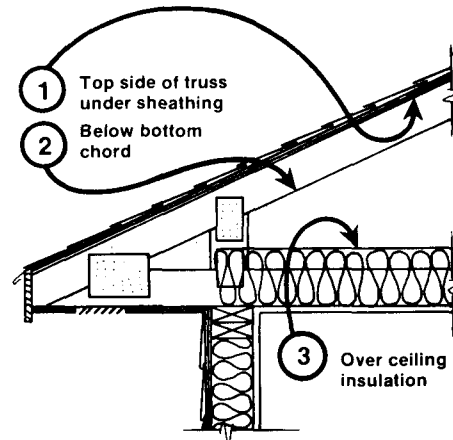

Figure 1. Typical attic section with three possible locations for a radiant barrier.

Multiple layers

Economics bode against more than one radiant barrier in attics. The first barrier surface eliminates about 95% of the radiant heat transfer across the attic. Adding more layers can affect only 95% of the remaining 5%. (This is not necessarily true in wall systems, where heat transfer by air convection can account for a greater percentage of total heat transfer — see wall systems section.)

Tightness

It is not necessary to form airtight seals with radiant barriers; radiant energy travels in a straight line **through**

the air but not *in* the air. In fact, if you choose location 3 (Figure 1), you should use a perforated foil product that will allow the free passage of vapor out of the insulation during winter. This may also apply to location 1 in some cases, because the barrier is in contact with the roof decking. Location 2 should not have moisture condensation problems because it has an airspace on both sides of the radiant barrier.

Exceptions

Roofs with their structure exposed to the living space — such as exposed-beam cathedral ceilings — usually require special treatment. Figure 2 shows two general approaches to this problem. Alternative A is a “vent-skin” roof construction — two distinct sheathing layers bounding an airspace that is vented with ambient air. Alternative B should not be vented. A similar approach to alternative A may be used when retrofitting roofs with low pitches and limited attic access space.

A true vent-skin roof, similar to alternative A, may also be used in conventional construction. In most conventional construction, however, this is not considered as cost effective as simple attic radiant barrier systems because of the additional material required and the limited additional performance benefits.

Commercial construction

Roofs of commercial buildings are usually quite different from residential roofs. They are usually flat, built-up roofs constructed of steel rather than wood. Commercial buildings often have suspended ceilings, above which are mechanical ductwork, electrical wiring and lighting systems. In many such buildings, roof and ceiling sections are poorly insulated and may have high infiltration rates.

Figure 3 shows an alternative to common commercial

roofing practice — an alternative that takes advantage of radiant barrier protection and places the ceiling plenum inside the conditioned space. If the ceiling plenum is still used for mechanical system ductwork, duct losses will be greatly reduced. In addition, by incorporating the continuous vapor barrier below the bar joists, the ceiling plenum can serve as an effective common return system, simplifying mechanical system design problems. The space above the rigid insulation can be ventilated for thermal and moisture control with relative impunity. This radiant barrier roof system can provide considerable energy savings in single-story commercial buildings where space conditioning is required.

Wall systems

Radiant barriers *must* face an airspace to work. Since walls — unlike roofs — don’t usually have air spaces, one must be created. In retrofits this is probably more easily done on the outside rather than inside of the wall for either wood-frame or block construction.

For new construction, interior radiant barrier systems may be more cost effective. For many climate conditions they will also be more efficient on an annual basis. (See Design Note 6, *Radiant Energy Transfer and Radiant Barrier Systems in Buildings*.) They are particularly applicable to frame-wall construction in northern environments where they can provide both thermal protection and a superior interior vapor barrier.

Massive walls that are used as the thermal storage component of passive systems obviously should not use internal radiant barrier systems. For energy conservation, however, where there is either no effective passive contribution or where thermal storage is provided by an alternative means, interior radiant barrier systems can

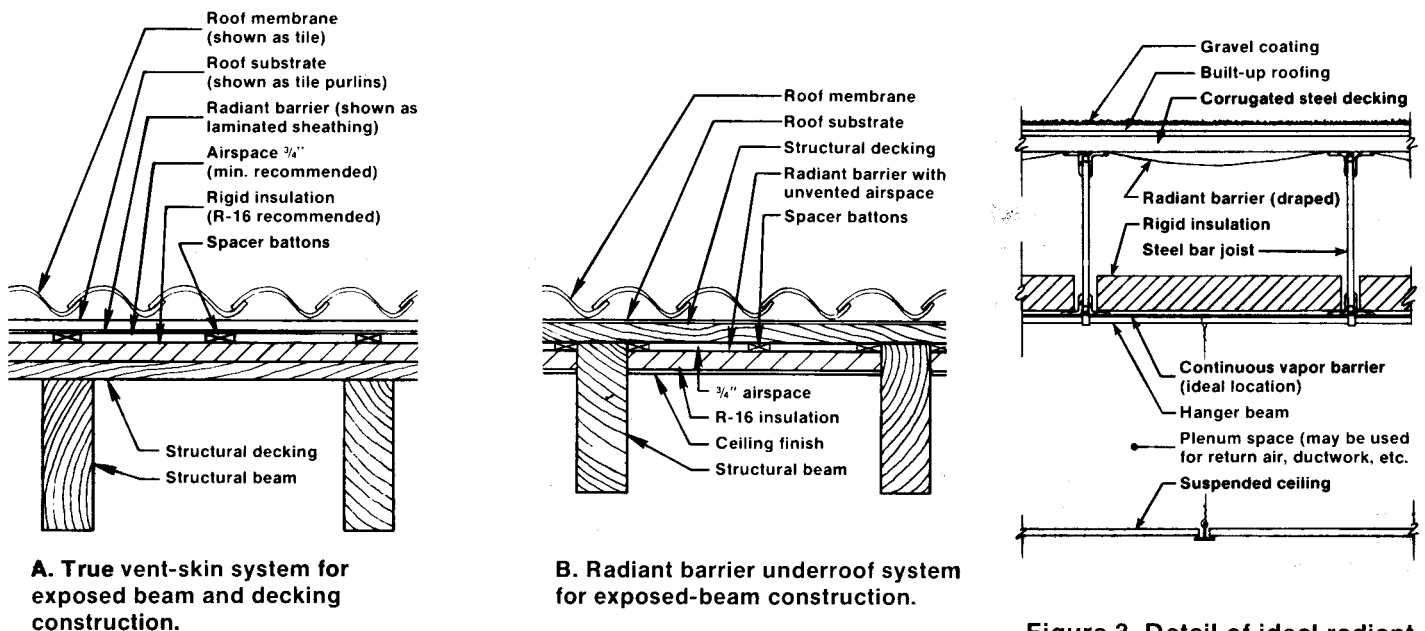

Figure 2. Constructions for exposed-beam cathedral ceilings.

Figure 3. Detail of ideal radiant barrier construction for typical flat-roof commercial building.

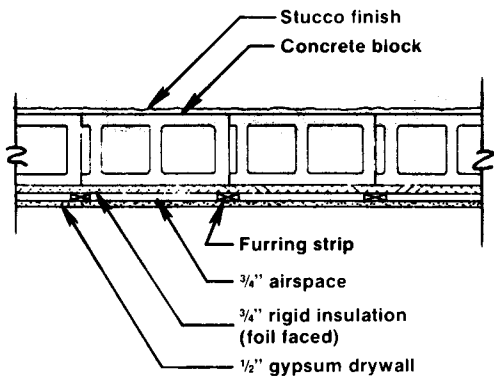

Figure 4. Plan view of interior radiant barrier system as applied to concrete block construction.

provide the most cost-effective conservation alternative for concrete-block wall systems.

Figure 4 gives a plan view of an interior radiant barrier system for block wall construction. The system uses standard building materials and standard construction practice to arrive at a superior thermal system. The airspace may still be used as a chaseway for electrical wiring without causing any significant performance degradation.

Exterior radiant barrier systems are more climate dependent than interior systems. For severe summer climates however, they can offer superior performance (see Design Note 6). Figure 5 shows the necessary parts of an effective exterior radiant barrier wall system. Only one airspace and radiant barrier are shown. This is all you need if you have other wall insulation. If not, you can use multiple-layer products. These can provide increased

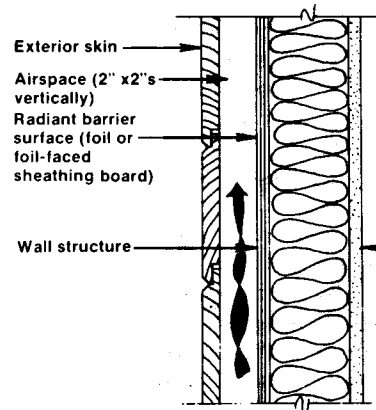

Figure 5. Partial studwall section with required components of an effective radiant barrier system.

resistance to heat flow in the same manner as do multiple-glazed windows.

Unlike interior systems, an exterior radiant barrier airspace may be vented or unvented. In summer, venting will improve cooling performance; the airspace temperature will remain lower. Figure 6 shows a system for venting an exterior radiant barrier airspace with ambient air. Because it is a vent skin, this wall system provides convective cooling of the airspace. When the airspace is warmed by the hot exterior skin, the air rises in the cavity and exhausts through the outlet. This draws cooler outside air in through the bottom vent.

In practice, FSEC has found that wind effects will quickly overcome any buoyancy pressure and will easily offset the thermal "stack" effect in this wall system. In addition, there is a potential for water damage caused by

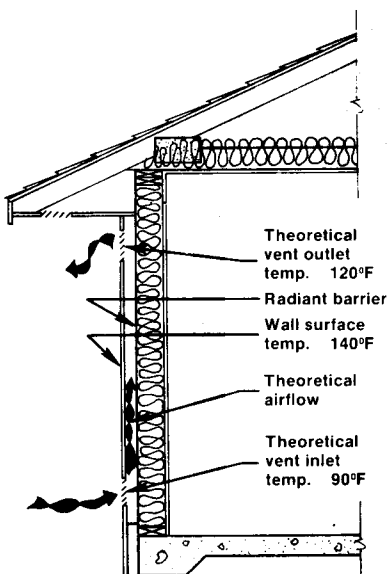

Figure 6. Vent-skin wall section. Wind pressure affects airflow more than stack effect.

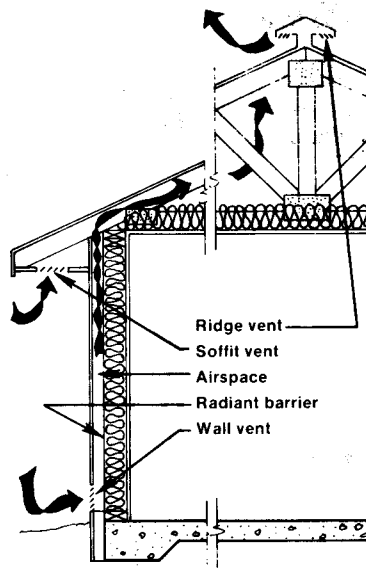

Figure 7. Improved vent-skin wall section. Wind and stack effect work together.

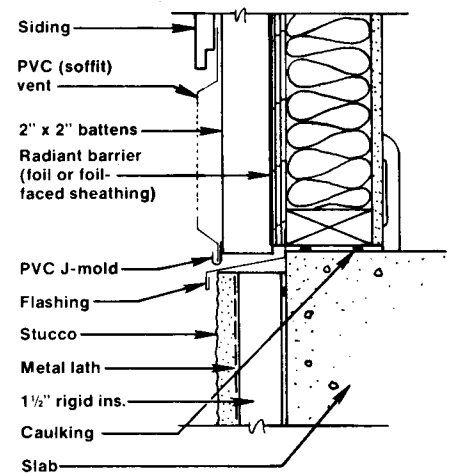

Figure 8. Detail of bottom inlet vent in vent-skin stud wall with radiant barrier.

rain intrusion at the upper vent. To get around these problems, locate the inlet and outlet vents in different wind regimes. Figure 7 shows how you can do this by directing the air at the top of the wall into the attic and out through a ridge vent. The outlet (roof ridge vent) is now in a lower pressure zone than is the inlet (bottom wall vent), and regardless of wind direction and fluctuations, the air in the wall and roof will always move upward. This stronger wind-driven force works in parallel with the natural thermal stack force, so the warmest air in the vent skin will be continuously removed at the roof ridge vent. This will flush the vent-skin airspace with ambient air entering at the bottom wall vent. Figure 8 depicts a method of providing a bottom wall vent.

Products and costs

Radiant barriers exist in a wide variety of products and costs. Many rigid insulation materials have an aluminum surface. Combined with an airspace they provide both a radiant barrier and resistance to conductive heat transfer. Tuff-R®, RMax® and Exeltherm® are examples. Costs for ¾" sheets of these materials range from \$.25 to \$.35 per square foot.

There are also laminated structural sheathing materials that have radiant barrier surfaces. Thermo-Bar®, Denny-Board®, and Thermo-Ply® are examples. They are often used as structural sheathing on residences and lack only an airspace in order to be used as a radiant barrier. Many of these products have only one reflective surface; care must be taken to ensure that it faces the airspace. Costs for these products range from \$.13 to \$.25 per square foot.

Another category of radiant barrier is generically called "builders foil." Builders foils consist of a thin foil layer laminated to a reinforcing substrate. They are available in single-sided and double-sided, perforated and unperforated varieties. Unperforated foils are excellent vapor barriers. They vary widely in cost from a low of \$.03 to a high of around \$.20 per square foot.

Your decision on which builders foil to use should be based on application. The lowest cost foils sometimes have very little tear resistance; they can be very difficult to install and hold in place in some applications. The thickness of the foil layer is also important. Foil layers thinner than .0005 inch are not recommended; they may have higher emissivities and they have a tendency to "powder" and fall off over time. Many builders foils have very strong substrates and can be used in almost any application.

Examples of available builders foils are C-Foil® by Reynolds Aluminum, Dennyfoil® by Denny Sales Corporation, Energy Clad Systems® by AAE Systems, Parsec Thermo-Brite® by Parsec, Inc., and FSK® by Lamtec Corporation. These products all have different prices and specifications; the manufacturer should be consulted before a product is specified.

Multilayer foil products are available from Alfoil, Inc., Foilpleat Insulation, Inc. and ESI Company. These products make use of trapped air layers/spaces between foil facings to inhibit convective as well as radiant heat

transfer. They are available with from two to five layers in a wide range of effective resistances. Their prices vary accordingly, from around \$.14 to \$.70 per square foot. Most of these products come folded or rolled. Their air-spaces are formed only when the product is stretched to its full width. Care must be taken in installation to ensure that they are sufficiently stretched and that foil layers are not touching or they will not be fully effective.

Most fiberglass insulation companies manufacture foil-faced batts. However, the binder that holds the insulation to the foil facing is usually a bituminous compound. This compound is **highly flammable**. The foil facings of such products are clearly marked. They should not be used for most radiant barrier applications because of their poor fire ratings.

Availability

A growing number of Florida building supply outlets sell radiant barrier products. Check with your local dealer or write to the Florida Solar Energy Center Public Information Office and ask for Fact Sheet 23. This free publication lists the dealers who have apprised the Center that they carry radiant barrier products. The publication is continually updated.

For further information

Fairey, Philip, *Radiant Energy Transfer and Radiant Barrier Systems in Buildings*, Design Note 6, Florida Solar Energy Center, Cape Canaveral, FL, June 1984.

Fairey, Philip, "Effects of Infrared Radiation Barriers on the Effective Thermal Resistance of Building Envelopes," proceedings of the ASHRAE/DOE Conference on Thermal Performance of the Exterior Envelopes of Buildings II, Las Vegas, NV, December 1982.

Fairey, Philip, et al., "The Thermal Performance of Selected Building Envelope Components in Warm, Humid Climates," proceedings of the 1983 ASME Solar Division Conference, Orlando, FL, April 1983.

Van Straaten, J.F., *Thermal Performance of Buildings*, Elsevier Publishing Company, New York (1967) pp. 142-160.

Wilkes, G. B., "Reflective Insulation," *Journal of Industrial and Engineering Chemistry*, 31D:832. July 1939.

© Copyright 1984 by Florida Solar Energy Center.